

MULTI GPU PROGRAMMING WITH CUDA AND MPI

Jiri Kraus, Senior Devtech Compute, April 25th 2017

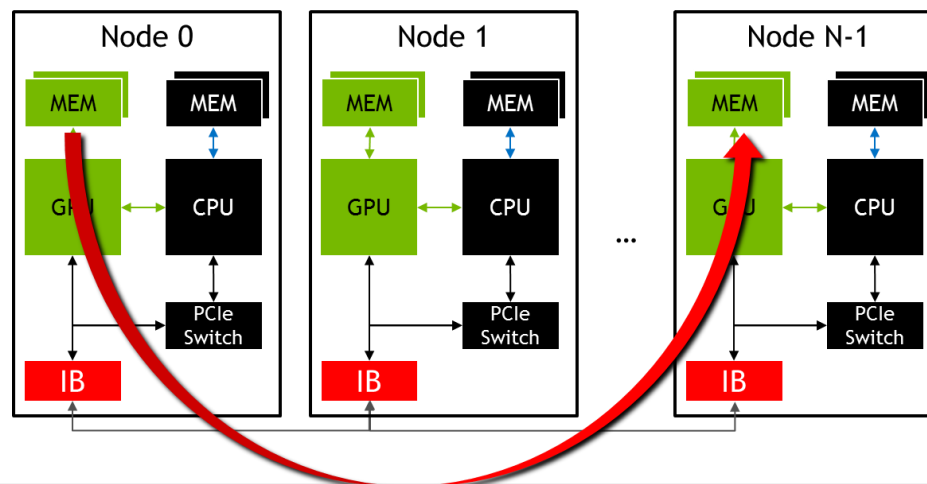

MPI+CUDA



```
//MPI rank 0
MPI_Send(sbuf_d, size, MPI_DOUBLE, n-1, tag, MPI_COMM_WORLD);

//MPI rank n-1
MPI_Recv(rbuf_d, size, MPI_DOUBLE, 0, tag, MPI_COMM_WORLD, MPI_STATUS_IGNORE);
```

USING MPI FOR INTER GPU COMMUNICATION

MESSAGE PASSING INTERFACE - MPI

Standard to exchange data between processes via messages

Defines API to exchanges messages

Point to Point: e.g. `MPI_Send`, `MPI_Recv`

Collectives: e.g. `MPI_Reduce`

Multiple implementations (open source and commercial)

Bindings for C/C++, Fortran, Python, ...

E.g. MPICH, OpenMPI, MVAPICH, IBM Platform MPI, Cray MPT, ...

MPI - SKELETON

```
#include <mpi.h>
int main(int argc, char *argv[]) {
    int rank, size;
    /* Initialize the MPI library */
    MPI_Init(&argc, &argv);
    /* Determine the calling process rank and total number of ranks */
    MPI_Comm_rank(MPI_COMM_WORLD, &rank);
    MPI_Comm_size(MPI_COMM_WORLD, &size);
    /* Call MPI routines like MPI_Send, MPI_Recv, ... */
    ...
    /* Shutdown MPI library */
    MPI_Finalize();
    return 0;
}
```

MPI

Compiling and Launching

```
$ mpicc -o myapp myapp.c  
$ mpirun -np 4 ./myapp <args>
```

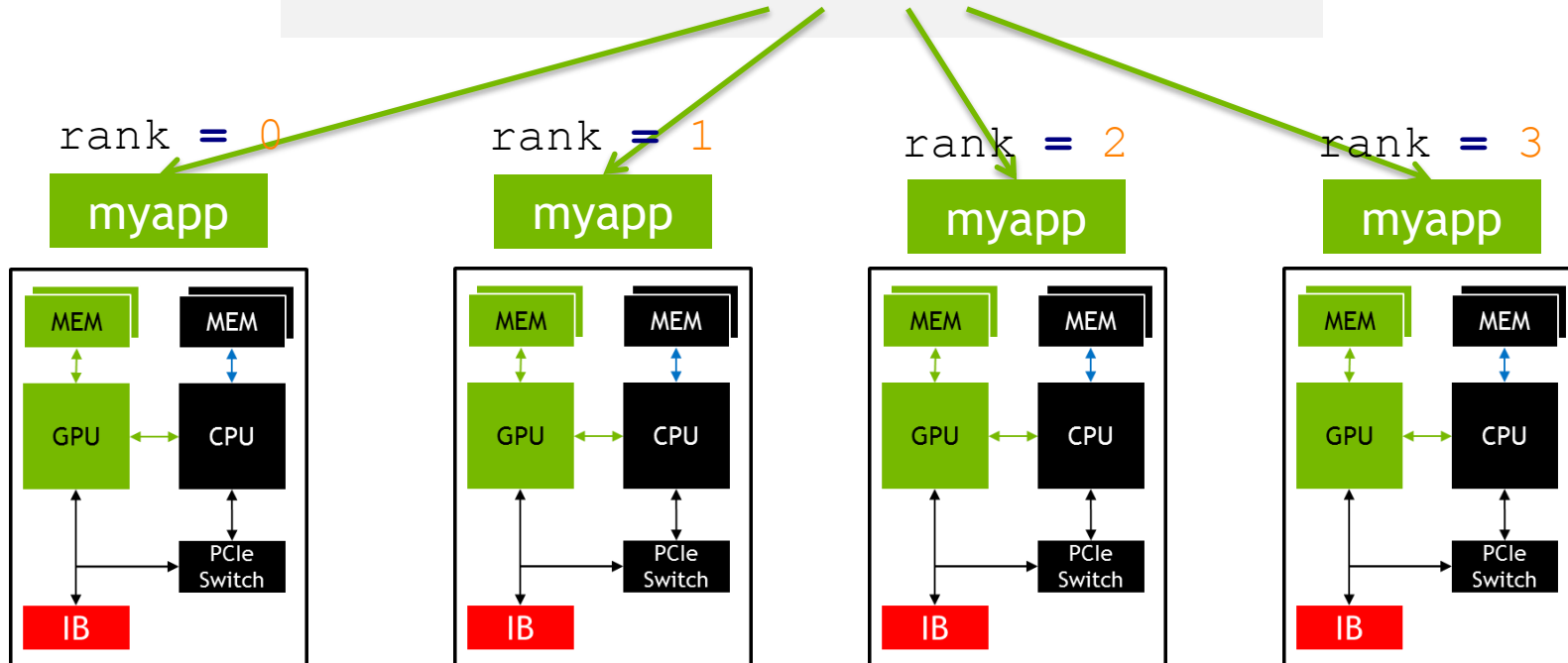

EXAMPLE: JACOBI SOLVER

Solves the 2D-Laplace Equation on a rectangle

$$\Delta \mathbf{u}(x, y) = \mathbf{0} \quad \forall (x, y) \in \Omega \setminus \delta\Omega$$

Dirichlet boundary conditions (constant values on boundaries) on left and right boundary

Periodic boundary conditions on top and bottom boundary

Domain decomposition with stripes

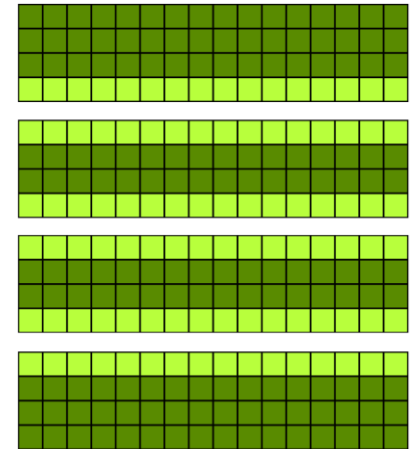

Horizontal Stripes

EXAMPLE: JACOBI SOLVER

Single GPU

While not converged

Do Jacobi step:

```
for (int iy = 1; iy < (ny-1); ++iy)
for (int ix = 1; ix < (nx-1); ++ix)
    a_new[iy*nx+ix] = 0.25f*((a[ iy  *nx + ix+1]+a[ iy  *nx + ix-1]
                               +a[(iy+1)*nx + ix]  +a[(iy-1)*nx + ix]));
```

Apply periodic boundary conditions

swap a_new and a

Next iteration

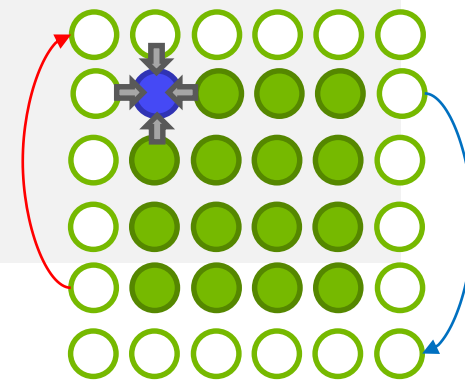

EXAMPLE: JACOBI SOLVER

Multi GPU

While not converged

Do Jacobi step:

```
for (int iy = iy_start; iy < iy_end; ++iy)
for (int ix = 1; ix < (nx-1); ++ix)

a_new[iy*nx+ix] = 0.25f*((a[ iy *nx + ix+1]+a[ iy *nx + ix-1]
                        +a[(iy+1)*nx + ix] +a[(iy-1)*nx + ix]));
```

Apply periodic boundary conditions and exchange halo with 2 neighbors

swap a_new and a

Next iteration

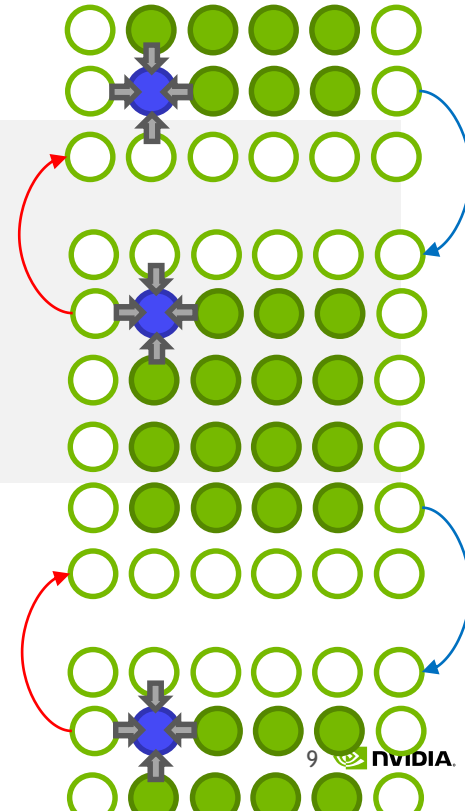

EXAMPLE JACOBI

Top/Bottom Halo

```
MPI_Sendrecv(a_new+iy_start*nx, nx, MPI_DOUBLE, top, 0,  
             a_new+iy_end*nx,   nx, MPI_DOUBLE, bottom, 0,  
             MPI_COMM_WORLD, MPI_STATUS_IGNORE);
```

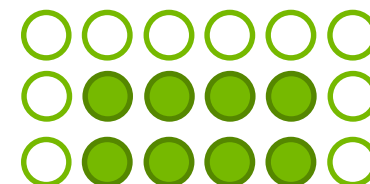
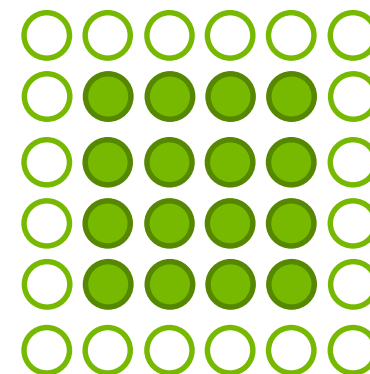
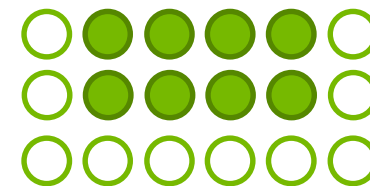

EXAMPLE JACOBI

Top/Bottom Halo

```
MPI_Sendrecv(a new+iy start*nx, nx, MPI_DOUBLE, top, 0,  
             a new+iy end*nx, nx, MPI_DOUBLE, bottom, 0,  
             MPI_COMM_WORLD, MPI_STATUS_IGNORE);
```

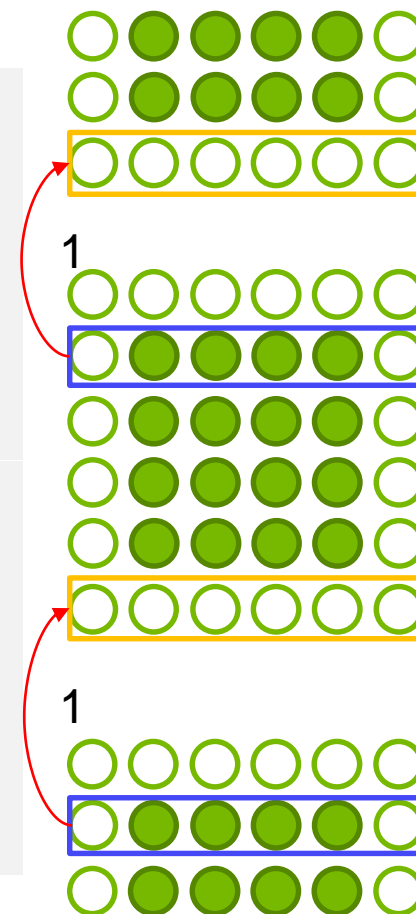

EXAMPLE JACOBI

Top/Bottom Halo

```
MPI_Sendrecv(a new+iy start*nx, nx, MPI_DOUBLE, top, 0,  
a new+iy end*nx, nx, MPI_DOUBLE, bottom, 0,  
MPI_COMM_WORLD, MPI_STATUS_IGNORE);
```

```
MPI_Sendrecv(a new+(iy end-1)*nx, nx, MPI_DOUBLE, bottom, 1,  
a new+(iy start-1)*nx, nx, MPI_DOUBLE, top, 1,  
MPI_COMM_WORLD, MPI_STATUS_IGNORE);
```

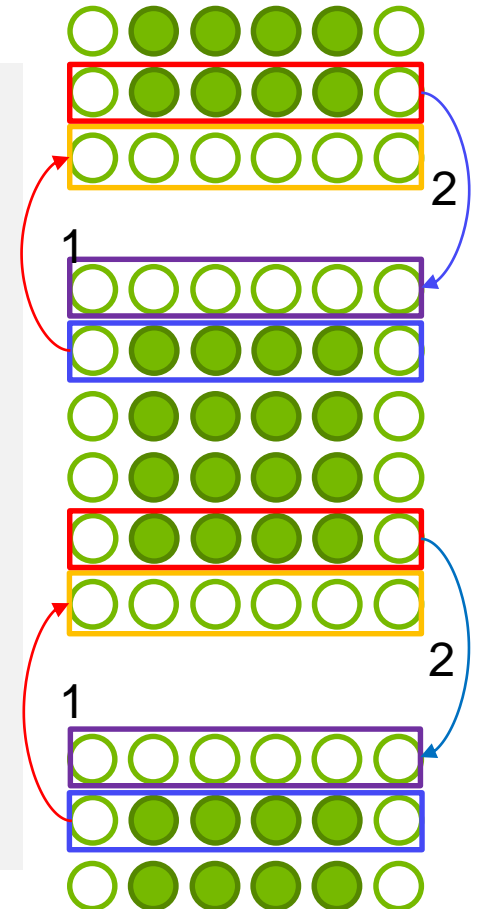

HANDLING MULTI GPU NODES

GPU-affinity

Use local rank:

```
int local_rank = //determine local rank  
  
int num_devices = 0;  
  
cudaGetDeviceCount (&num_devices);  
  
cudaSetDevice (local_rank % num_devices);
```

HANDLING MULTI GPU NODES

How to determine the local rank? - MPI-3

```
MPI_Comm local_comm;  
  
MPI_Info info;  
  
MPI_Info_create(&info);  
  
MPI_Comm_split_type(MPI_COMM_WORLD, MPI_COMM_TYPE_SHARED, rank, info, &local_comm);  
  
int local_rank = -1;  
  
MPI_Comm_rank(local_comm, &local_rank);  
  
MPI_Comm_free(&local_comm);  
  
MPI_Info_free(&info);
```

PROFILING OF MPI+CUDA APPS

PROFILING MPI+CUDA APPLICATIONS

Using `nvprof`+`NVVP`

Embed MPI rank in output filename, process name, and context name

```
mpirun -np $np nvprof --output-profile profile.%q{OMPI_COMM_WORLD_RANK} \
      --process-name "rank %q{OMPI_COMM_WORLD_RANK}" \
      --context-name "rank %q{OMPI_COMM_WORLD_RANK}"
```

Alternative:

Only save the textual output (`--log-file`)

OpenMPI: `OMPI_COMM_WORLD_RANK`

MVAPICH2: `MV2_COMM_WORLD_RANK`

PROFILING MPI+CUDA APPLICATIONS

Using `nvprof`+`NVVP`

```
jkraus@hpcwur: ~/workspace/p4code/edu/Multi_GPU_Programming_with_MPI_and_CUDA/solution2
jkraus@hpcwur:~/workspace/p4code/edu/Multi_GPU_Programming_with_MPI_and_CUDA/solution2$ make profile
mpirun -np 2 nvprof -o jacobi.%q{OMPI_COMM_WORLD_RANK}.nvprof --process-name "rank %q{OMPI_COMM_WORLD_RANK}" --context-name "rank %q{OMPI_COMM_WORLD_RANK}" ./jacobi -niter 10
==3036== NVPROF is profiling process 3036, command: ./jacobi -niter 10
==3038== NVPROF is profiling process 3038, command: ./jacobi -niter 10
Single GPU jacobi relaxation: 10 iterations on 1024 x 1024 mesh
    0, 7.996098
Jacobi relaxation: 10 iterations on 1024 x 1024 mesh
    0, 63.937496
Num GPUs: 2.
1024x1024: 1 GPU: 0.0251 s, 2 GPUs: 0.0694 s, speedup: 0.36, efficiency: 18.08
==3038== Generated result file: /home/jkraus/Perforce/swdevrel-jkraus_HPCWUR/sw/devrel/Playpen/jkraus/code/edu/Multi_GPU_Programming_with_MPI_and_CUDA/solution2/jacobi.1.nvprof
==3036== Generated result file: /home/jkraus/Perforce/swdevrel-jkraus_HPCWUR/sw/devrel/Playpen/jkraus/code/edu/Multi_GPU_Programming_with_MPI_and_CUDA/solution2/jacobi.0.nvprof
jkraus@hpcwur:~/workspace/p4code/edu/Multi_GPU_Programming_with_MPI_and_CUDA/solution2$
```

PROFILING MPI+CUDA APPLICATIONS

Using `nvprof`+NVVP

Use the import Wizard

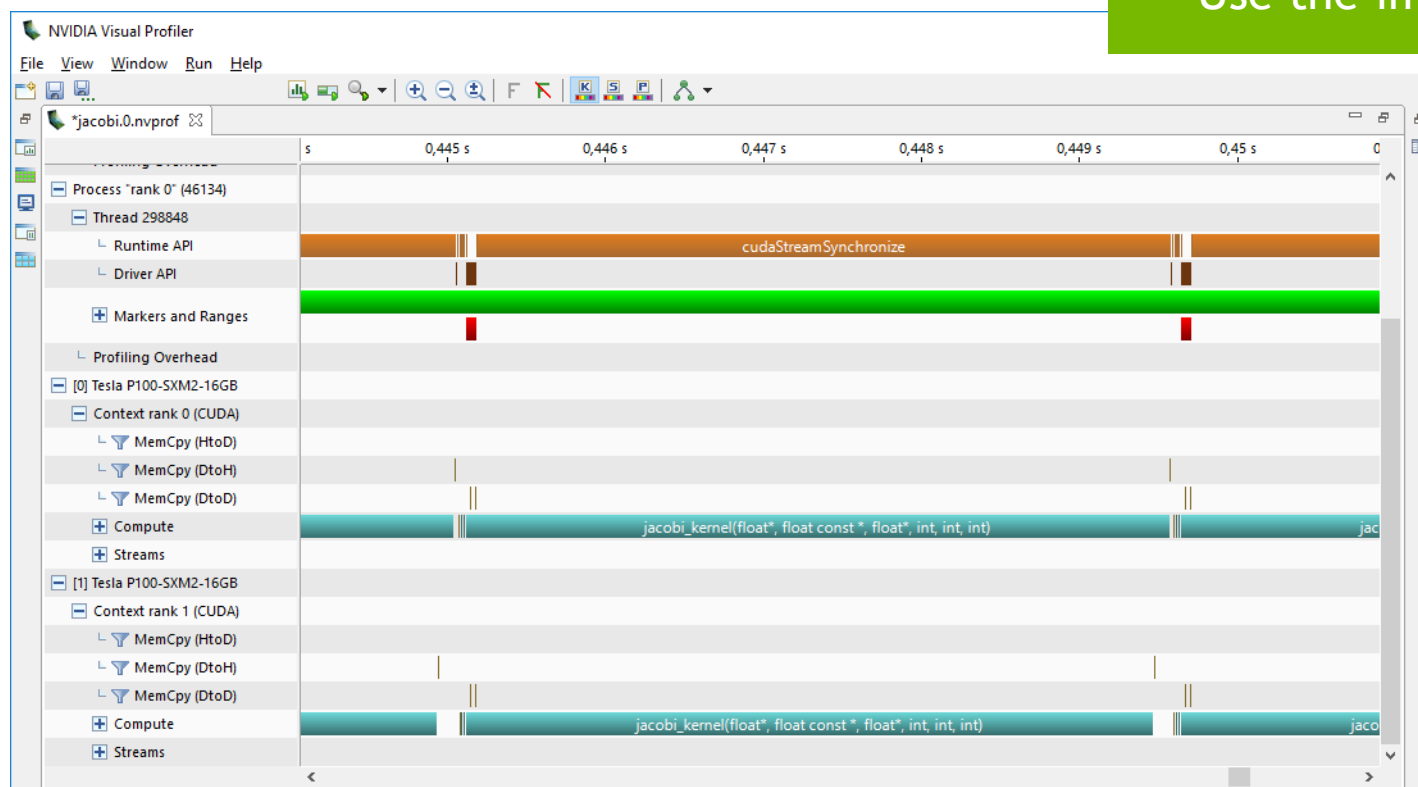

PROFILING MPI+CUDA APPLICATIONS

Third Party Tools

Multiple parallel profiling tools are CUDA-aware

Score-P

Vampir

Tau

These tools are good for discovering MPI issues as well as basic CUDA performance inhibitors.

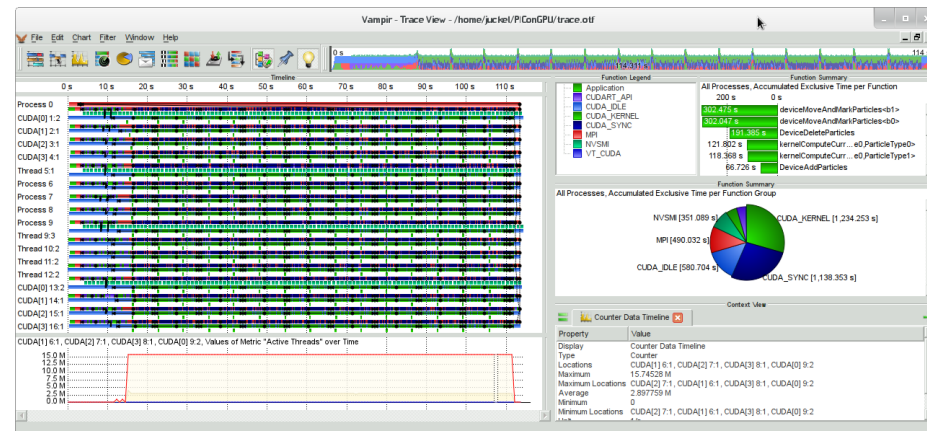
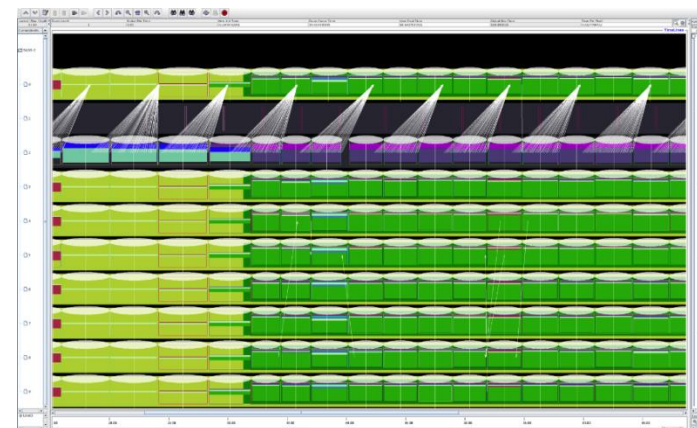

OVERLAPPING MPI AND COMPUTATION

COMMUNICATION + COMPUTATION OVERLAP

OpenMPI 1.10.2 - 2 Tesla K40

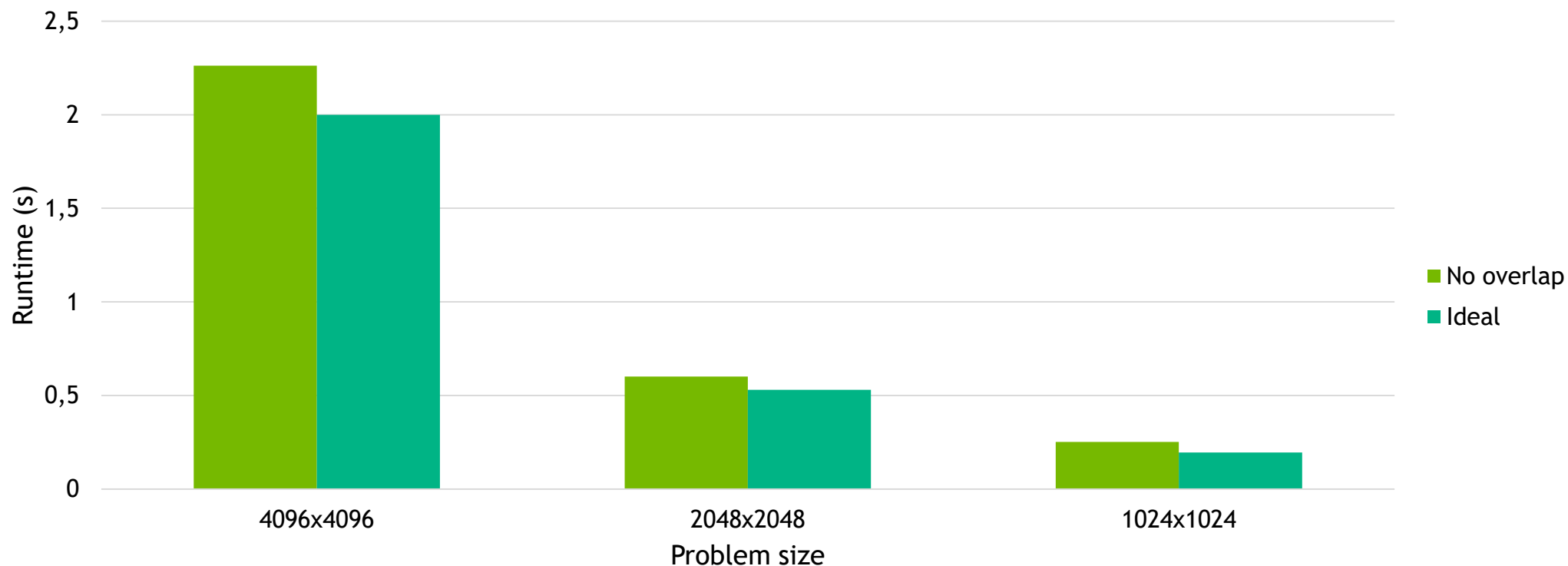

COMMUNICATION + COMPUTATION OVERLAP

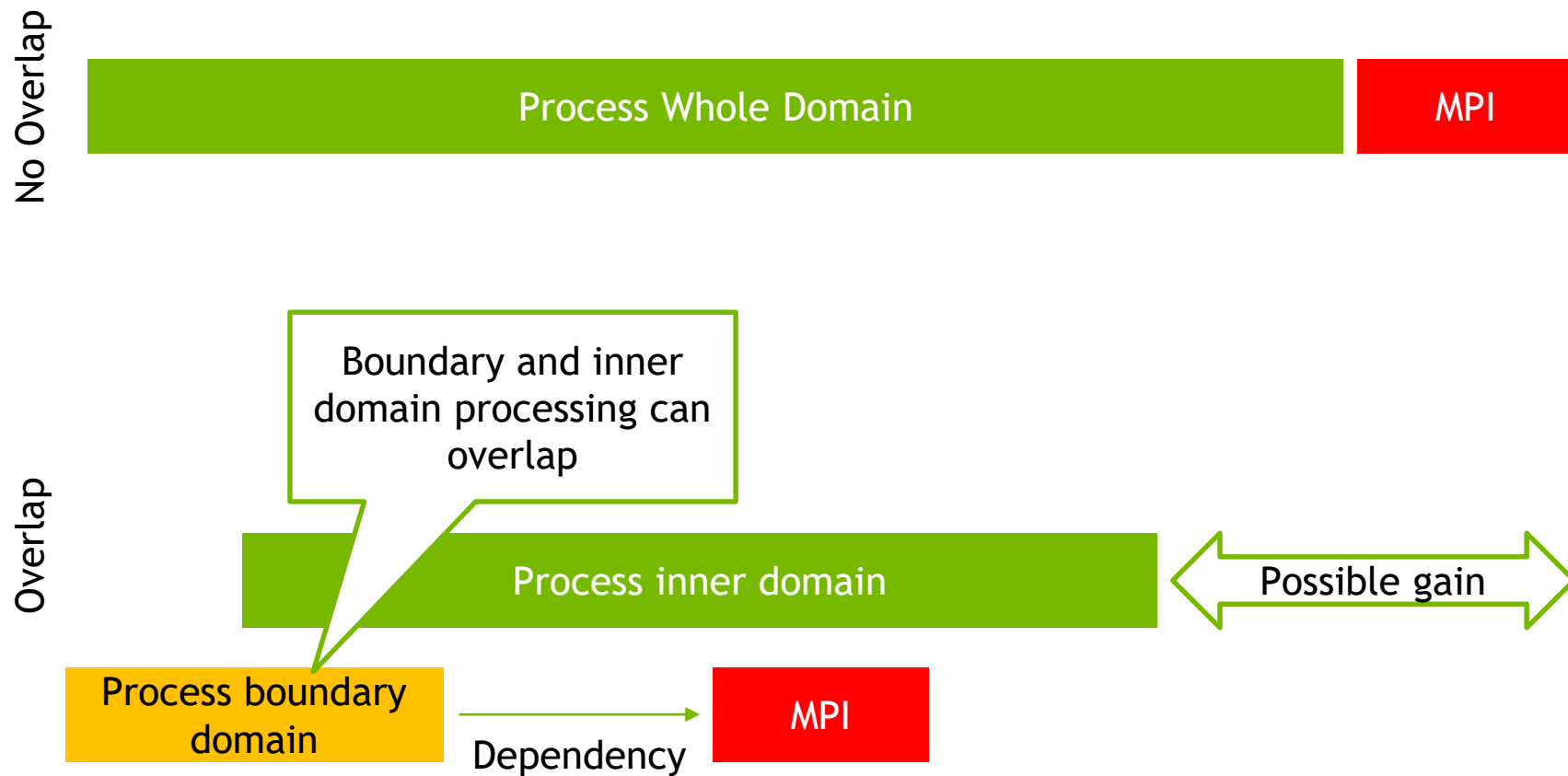

COMMUNICATION + COMPUTATION OVERLAP

Asynchronous execution with CUDA streams

```
launch_jacobi_kernel( a_new, a, l2_norm_m, iy_start, (iy_start+1), nx, halo_stream );
launch_jacobi_kernel( a_new, a, l2_norm_m, (iy_end-1), iy_end, nx, halo_stream );
launch_jacobi_kernel( a_new, a, l2_norm_m, (iy_start+1), (iy_end-1), nx, compute_stream );
int top = rank > 0 ? rank - 1 : (size-1); int bottom = (rank+1)%size;
//Apply periodic boundary conditions
cudaStreamSynchronize( halo_stream );
MPI_Sendrecv( a_new+iy_start*nx, nx, MPI_REAL_TYPE, top, 0,
              a_new+(iy_end*nx), nx, MPI_REAL_TYPE, bottom, 0,
              MPI_COMM_WORLD, MPI_STATUS_IGNORE );
MPI_Sendrecv( a_new+(iy_end-1)*nx, nx, MPI_REAL_TYPE, bottom, 0,
              a_new+(iy_start-1)*nx, nx, MPI_REAL_TYPE, top, 0,
              MPI_COMM_WORLD, MPI_STATUS_IGNORE );
cudaStreamSynchronize( compute_stream );
```

COMMUNICATION + COMPUTATION OVERLAP

OpenMPI 1.10.2 - 2 Tesla K40

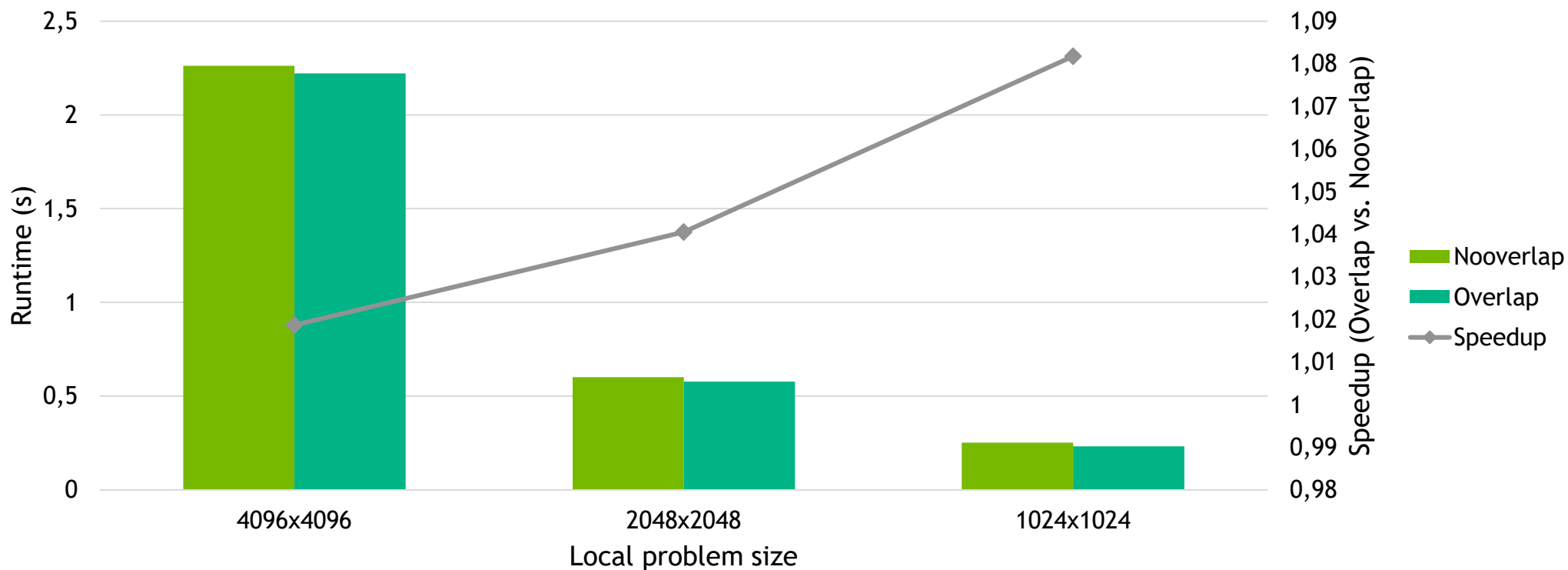

MPI AND UNIFIED MEMORY

MPI AND UNIFIED MEMORY

CAVEAT

Using Unified Memory with a non Unified Memory-aware MPI might break in some cases, e.g. when registering memory for RDMA, or even worse silently produce wrong results.



Use a Unified Memory-aware MPI with Unified Memory and MPI

Unified Memory-aware: CUDA-aware MPI with support for Unified Memory

MPI AND UNIFIED MEMORY

Current Status

Available Unified Memory-aware MPI implementations

- OpenMPI (since 1.8.5)
- MVAPICH2-GDR (since 2.2b)
 - Performance improvements with 2.2RC1 for Intranode GPU to GPU communication

Currently both treat all Unified Memory as Device Memory



Good performance if all buffers used in MPI are touched mainly on the GPU.

MPI AND UNIFIED MEMORY

Without Unified Memory-aware MPI

Only use non Unified Memory Buffers for MPI: `cudaMalloc`, `cudaMallocHost` or `malloc`

Application managed non Unified Memory Buffers also allow to work around current missing cases in Unified Memory-aware MPI Implementations.

HANDS-ON

HANDS-ON MENU

4 tasks to choose from

Task 0: Using MPI

Task 1: Handle GPU Affinity

Task 2: Apply Domain Decomposition

Task 3: Overlap MPI and Compute

TASK 0: USING MPI

task0

Determine rank (`MPI_Comm_rank`) and size (`MPI_Comm_size`)

Add `MPI_Barrier` to ensure correct timing

Look for TODOs

```
Num GPUs: 1.  
2048x2048: 1 GPU: 18.9308 s, 1 GPUs: 18.8297 s, speedup:  
Num GPUs: 1.  
2048x2048: 1 GPU: 18.9888 s, 1 GPUs: 18.8055 s, speedup:
```

Make Targets:

```
run:          run jacobi with $NP procs.  
jacobi:       build jacobi bin (default)  
memcheck:     profile with cuda-memcheck  
profile:      profile with nvprof  
Solution is in solution0
```

<https://www.open-mpi.org/doc/current/>

TASK 1: HANDLING GPU AFFINITY

task1

Handle GPU affinity with `MPI_COMM_TYPE_SHARED`

Run and report the performance

Look for TODOs

```
900, 0.061306
Num GPUs: 2.
2048x2048: 1 GPU: 18.9678 s, 2 GPUs: 18.8432 s, speedup: 1.01
```

Make Targets:

```
run:      run jacobi with $NP procs.
jacobi:   build jacobi bin (default)
memcheck: profile with cuda-memcheck
profile:  profile with nvprof
Solution is in solution1
```

<https://www.open-mpi.org/doc/current/>

TASK 2: APPLY DOMAIN DECOMPOSITION

task2

Calculate first (`iy_start`) and last (`iy_end`) row to be processed by each rank

Use `MPI_Sendrecv` to handle halo updates and periodic boundary conditions

Use `MPI_Allreduce` to calculate global L2 norm

Look for TODOs

```
900, 0.061306
Num GPUs: 2.
2048x2048: 1 GPU: 8.7768 s, 2 GPUs: 8.7579 s, speedup: 1.00
```

Make Targets:

```
run:      run jacobi with $NP procs.
jacobi:   build jacobi bin (default)
memcheck: profile with cuda-memcheck
profile:  profile with nvprof
Solution is in solution2
```

<https://www.open-mpi.org/doc/current/>

TASK 3: OVERLAP MPI AND COMPUTE

task3

Use `cudaStreamCreate` to create halo processing stream

Split jacobi step in top boundary, bottom boundary and bulk part

Launch top and bottom boundary part in halo processing stream

Look for TODOs

```
900, 0.061310
Num GPUs: 2.
2048x2048: 1 GPU: 8.8221 s, 2 GPUs: 4.4896 s, speedup: 1.97
```

Make Targets:

```
run:      run jacobi with $NP procs.
jacobi:   build jacobi bin (default)
memcheck: profile with cuda-memcheck
profile:  profile with nvprof
Solution is in solution3
```

<https://www.open-mpi.org/doc/current/>

SOLUTIONS

TASK 0: USING MPI

Solution

```
int main(int argc, char * argv[]) {
    int rank = 0;
    int size = 1;
    MPI_CALL( MPI_Init(&argc,&argv) );
    MPI_CALL( MPI_Comm_rank(MPI_COMM_WORLD,&rank) );
    MPI_CALL( MPI_Comm_size(MPI_COMM_WORLD,&size) );
    //...
    MPI_CALL( MPI_Barrier(MPI_COMM_WORLD) );
    double start = MPI_Wtime();
    while ( l2_norm > tol && iter < iter_max )
    //...
    MPI_CALL( MPI_Finalize() );
    return result_correct == 1 ? 0 : 1; }
```

TASK 1: HANDLING GPU AFFINITY

Solution

```
int dev_id = -1;
{
    MPI_Comm local_comm;
    MPI_Info info;
    MPI_CALL( MPI_Info_create(&info) );
    MPI_CALL( MPI_Comm_split_type(MPI_COMM_WORLD, MPI_COMM_TYPE_SHARED,
                                   rank, info, &local_comm) );
    MPI_CALL( MPI_Comm_rank(local_comm, &dev_id) );
    MPI_CALL( MPI_Comm_free(&local_comm) );
    MPI_CALL( MPI_Info_free(&info) );
}

CUDA_RT_CALL( cudaSetDevice( dev_id ) );
```

TASK 2: APPLY DOMAIN DECOMPOSITION

Solution I

```
// Ensure correctness if ny%size != 0
int chunk_size = std::ceil( (1.0*ny)/size );
int iy_start = rank*chunk_size;
int iy_end = iy_start+chunk_size;
// Do not process boundaries
iy_start = std::max( iy_start, 1 );
iy_end = std::min( iy_end, ny - 1 );
```

TASK 2: APPLY DOMAIN DECOMPOSITION

Solution II

```
//Apply periodic boundary conditions
CUDA_RT_CALL( cudaStreamSynchronize( compute_stream ) );
PUSH_RANGE("MPI",5)
MPI_CALL( MPI_Sendrecv( a_new+iy_start*nx, nx, MPI_REAL_TYPE, top, 0,
                        a_new+(iy_end*nx), nx, MPI_REAL_TYPE, bottom, 0,
                        MPI_COMM_WORLD, MPI_STATUS_IGNORE ) );
MPI_CALL( MPI_Sendrecv( a_new+(iy_end-1)*nx, nx, MPI_REAL_TYPE, bottom, 0,
                        a_new+(iy_start-1)*nx, nx, MPI_REAL_TYPE, top, 0,
                        MPI_COMM_WORLD, MPI_STATUS_IGNORE ) );
POP_RANGE
```

TASK 2: APPLY DOMAIN DECOMPOSITION

Solution III

```
CUDA_RT_CALL( cudaStreamSynchronize( compute_stream ) );  
MPI_CALL( MPI_Allreduce( l2_norm_m, &l2_norm, 1, MPI_REAL_TYPE,  
                        MPI_SUM, MPI_COMM_WORLD ) );  
l2_norm = std::sqrt( l2_norm );
```

TASK 3: OVERLAP MPI AND COMPUTE

Solution

```
launch_jacobi_kernel( a_new, a, l2_norm_d,
                      iy_start, (iy_start+1), nx, halo_stream );
launch_jacobi_kernel( a_new, a, l2_norm_d,
                      (iy_end-1), iy_end, nx, halo_stream );
launch_jacobi_kernel( a_new, a, l2_norm_d, (iy_start+1),
                      (iy_end-1), nx, compute_stream );
int top = rank > 0 ? rank - 1 : (size-1); int bottom = (rank+1)%size;
//Apply periodic boundary conditions
CUDA_RT_CALL( cudaStreamSynchronize( halo_stream ) );
PUSH_RANGE("MPI",5)
MPI_CALL( MPI_Sendrecv( a_new+iy_start*nx, ...
```

TASK 3: OVERLAP MPI AND COMPUTE

Solution

